

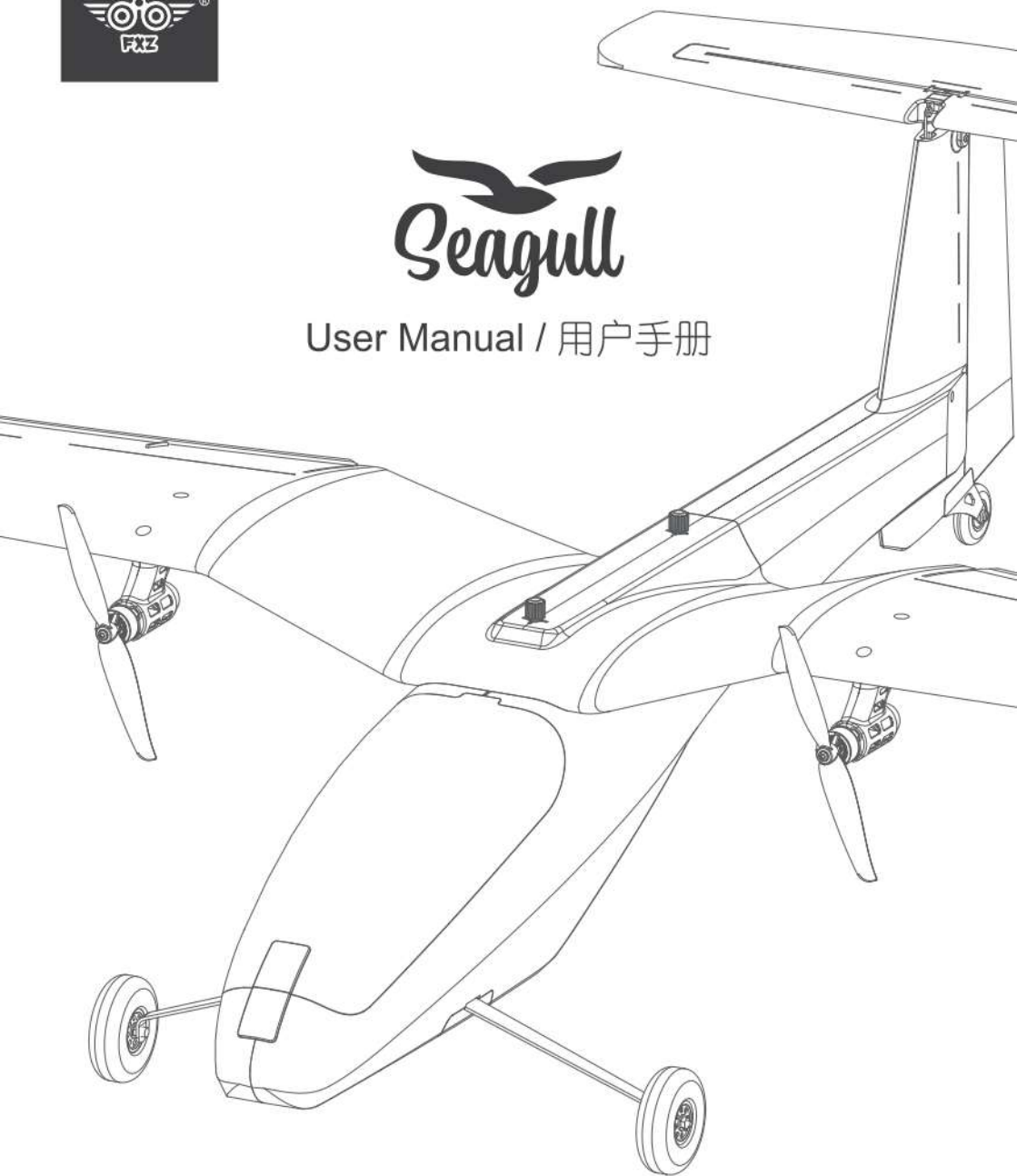

Seagull

User Manual / 用户手册



E sky[®]

Safety Precautions and Warnings

This RC aircraft is controlled by radio signals. Other radio signals can potentially interfere with its operation. These interference may cause the aircraft lose control.

 Warning

1. Improper operation of ESKY Seagull may lead to damage or loss. It is prohibited for children under 14 years to operate this product.
2. Keep it away from high temperature environments for storage and flight.
3. Suggested operation temperature: 5-35°C , Humidity: 20-80%.
4. Keep away from fans, air conditioners and table light while flying.
5. Do not touch the motor in case of damage or injury.

 Prohibition

1. Keep away from crowds to prevent accidents.
2. Do not operate ESKY Seagull in the shower room or in rain. Moisture may get inside the aircraft which may cause electronic parts to malfunction.
3. Do not re-equip or repair your aircraft with unauthorized parts.
4. Keep people and objects away from the spinning unit and parts to prevent of damage or injury.

Table of Contents

Specifications & Configuration & Box Contents	3
Battery Charging	4
Aircraft Parts	4
Model Assembly - Main Landing Gear Installation	5
Model Assembly - Horizontal Tail Installation	5
Model Assembly - Wing Installation	6
Control Surface Centering	7
Center of Gravity (CG)	8
Pre-Flight Checklist	8
Flying Checklist	9
Multi Control Unit Wiring Diagram	9
Transmitter and Receiver Binding	10
Troubleshooting Guide	10
MINI 6X Transmitter - Mode2 (Required to Complete)	11
MINI 6X Transmitter - Mode1 (Required to Complete)	11
MINI 6X Transmitter Control Direction - Mode2 (Required to Complete)	12
MINI 6X Transmitter Control Direction - Mode1 (Required to Complete)	13
Parts Listing	14

Specifications

Wing Span	760mm	Flying Time	8-15 Minutes
Length	643mm	Main Material	EPP
Flying Weight	247g	Battery connector	JST SYP 2.5mm 2-Pin

Configuration (BTF)

Motor	1104-4275Kv Brushless Outrunner	Receiver	ESKY Multi Controller
ESC	15A BEC 3A	Flight Control	ESKY Multi Controller
Battery	2S 650mAh 20C	Battery Charger	2S Balance Charger
Servo	4.3g Digital Servo x3	Transmitter	Required to Complete (MINI 6X or ECH6 Transmitter)

Box Contents

1 x Wing with Motors and Propellers	1 x Horizontal Tail
1 x Fuselage	2 x Main Landing Gear
1 x 2S Battery Charger	1 x 650mAh 2S Li-Po Battery
2 x Wing Fixing Bolt	

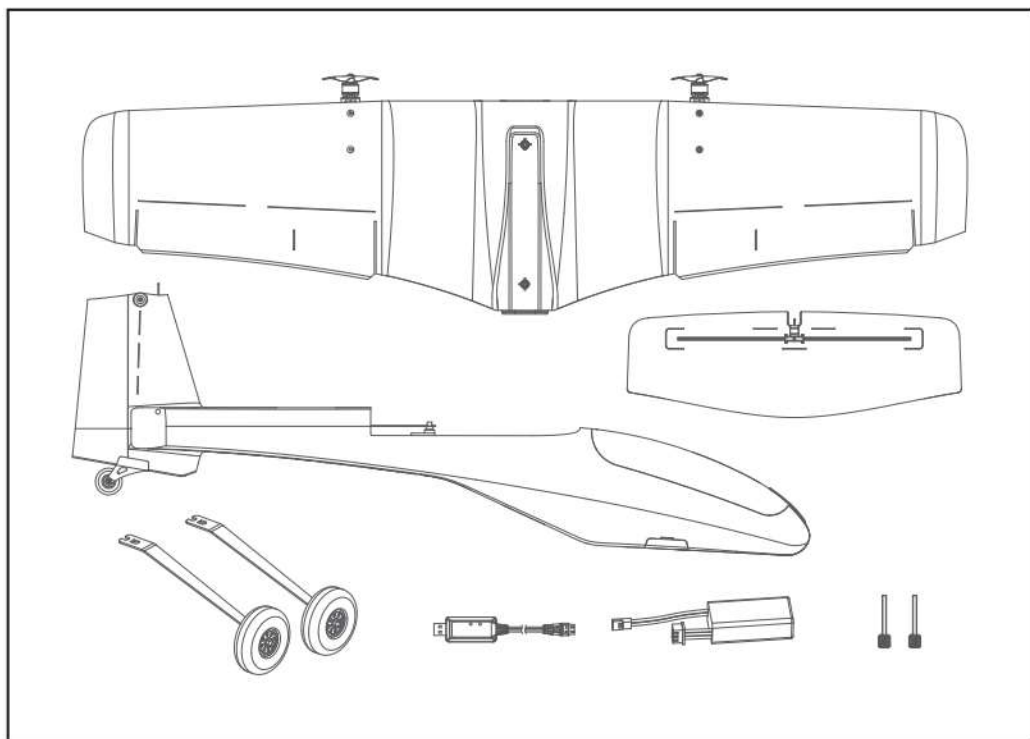

Battery Charging

- 1) Connect the LiPo Battery to the charger and connect the charger to the USB port or a USB power supply.
- 2) The LED on the charger will glow solid red and blinking green, indicating charging has begun.
- 3) When the LiPo Battery is fully charged, the LED will glow solid red and solid green.

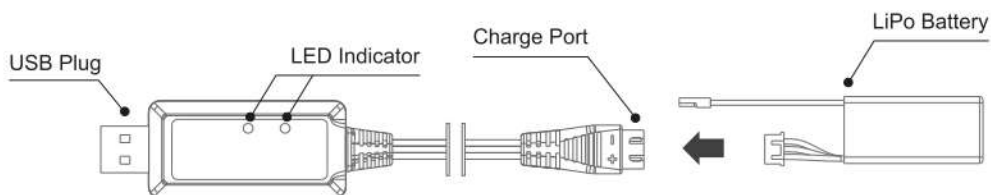

Red Solid and Green Blinking LED: Charging

Red and Green Solid LED: Charging Complete

Red Solid LED: Power Connected (Stand By)

Red Blinking LED Only: Battery Error

Red and Green Blinking LED: Charger Error

Red Blinking and Green Solid LED: Input (V) too high

Aircraft Parts

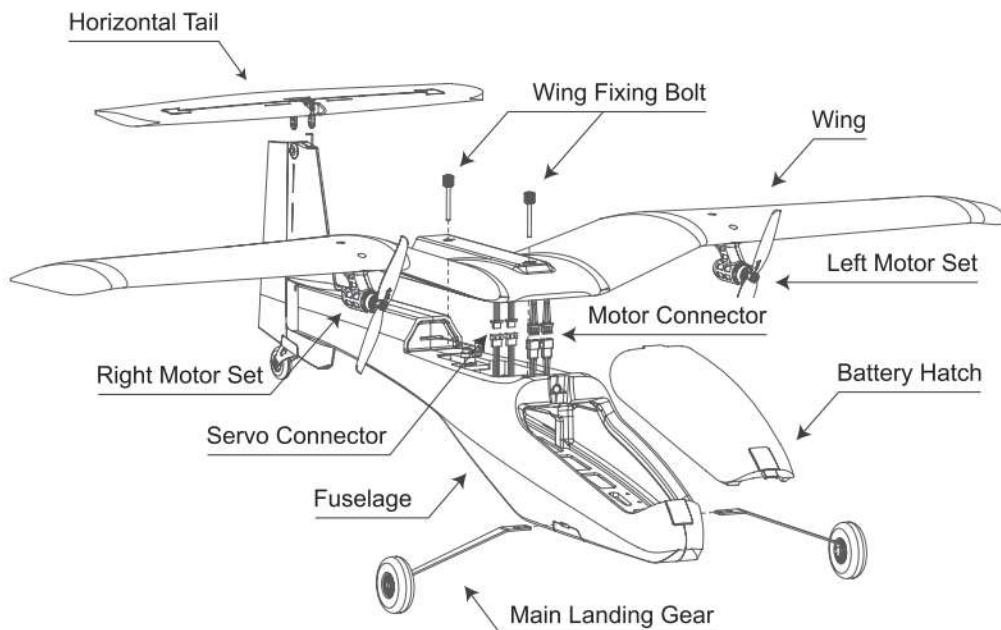

Model Assembly - Main Landing Gear Installation

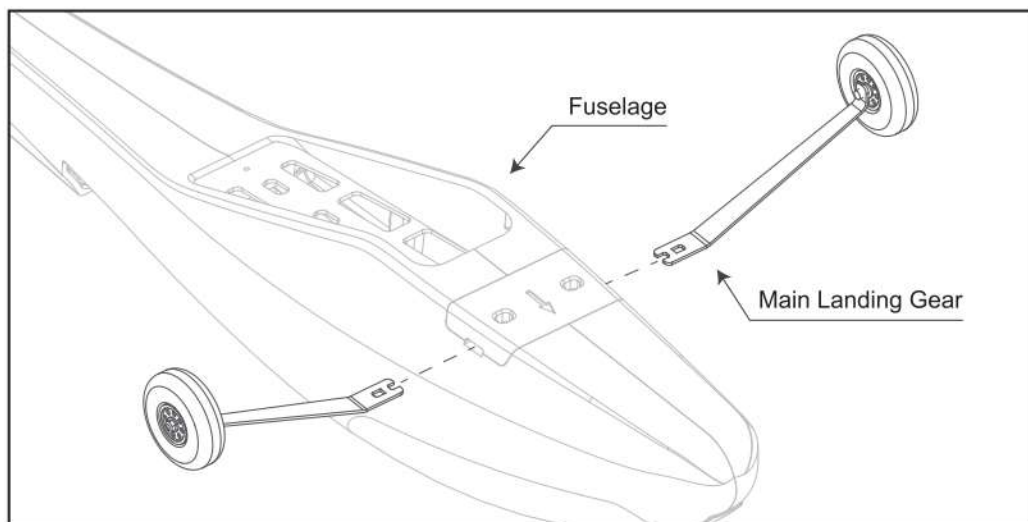

Slide the main landing gears into the slots in the side of the fuselage until they lock into place as shown.

Model Assembly - Horizontal Tail Installation

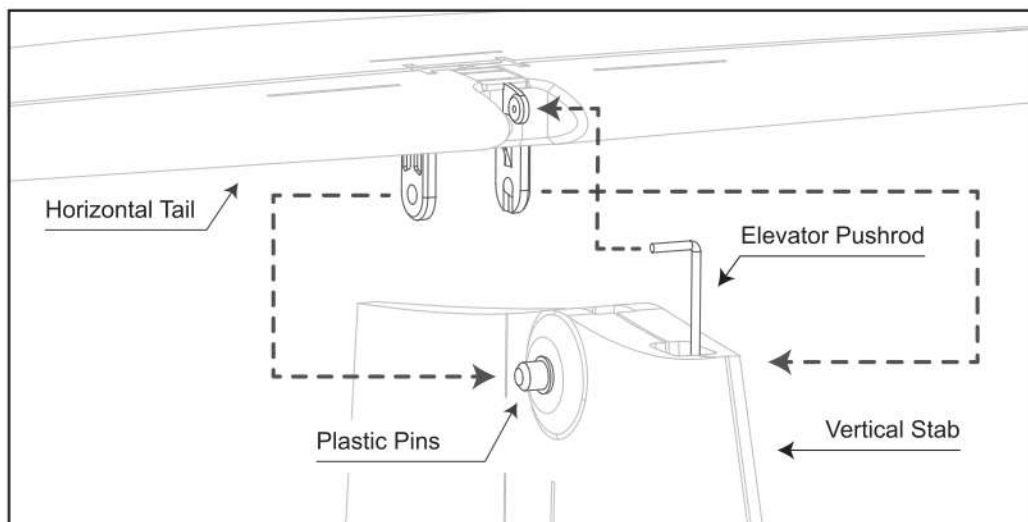

Attach the end of the elevator pushrod at the top of the vertical stab into the corresponding hole in the center of the horizontal tail. Connect the plastic pins at the top of the vertical stab into the respective clevis holes at the bottom of the horizontal tail.

Model Assembly - Wing Installation

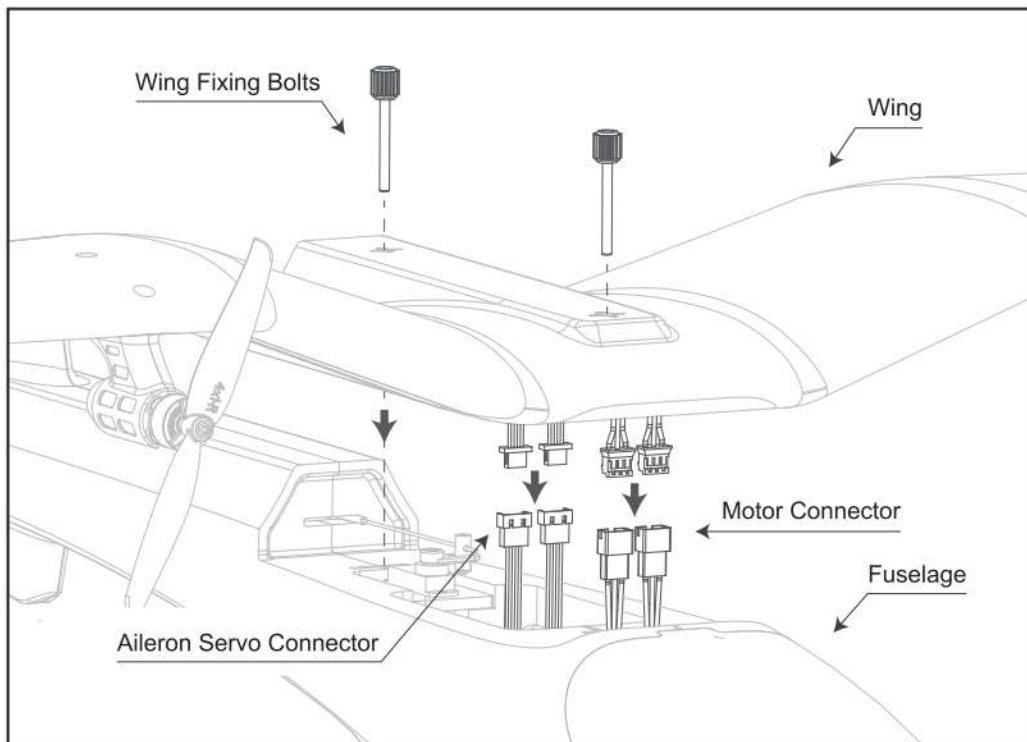

Connect the aileron servo connectors and motor connectors to the aileron servo extensions and motor extensions installed in the multi controller and center the wing on the fuselage. Ensure the aileron servo connectors and motor connectors are not pinched between the wing and fuselage.

Then attach the wing with the included wing fixing bolts. Do not overtighten the wing bolts, as it may damage the wing or the attachment points in the fuselage.

Seagull Installation Complete

Control Surface Centering (Aircraft was completely adjusted in the factory setting)

Turn off the transmitter and plug the flight battery into the aircraft (all the servo will return to neutral position automatically) before performing control surface centering.

Aileron Adjustment

Unscrewing the pushrod mounting screw under the wing, adjust the aileron until the control surface is centered, screwing in the pushrod mounting screw after adjustment.

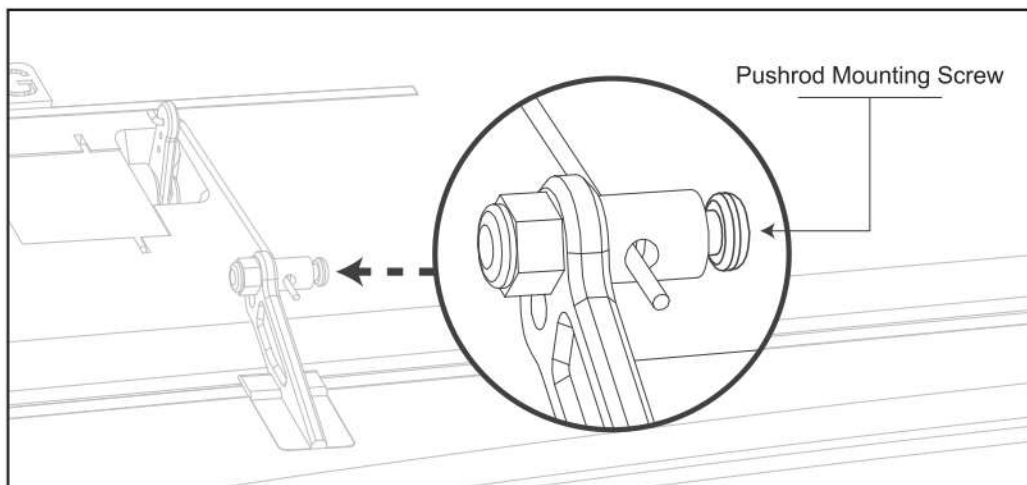

Horizontal Tail Adjustment

Unscrew the pushrod mounting screw on the servo and adjust the horizontal tail until the line on the clevises aligns with the line on the vertical stab as shown, tighten the pushrod mounting screw after adjustment.

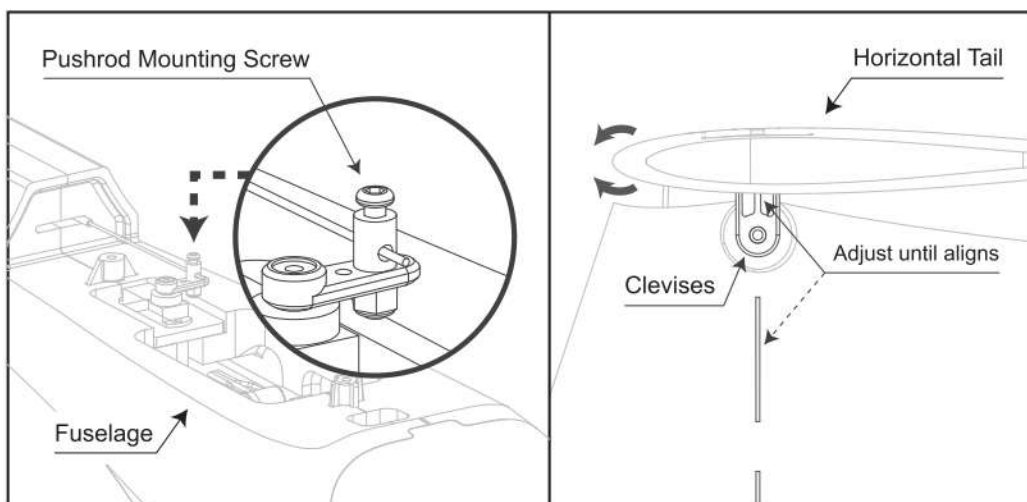

Center of Gravity (CG)

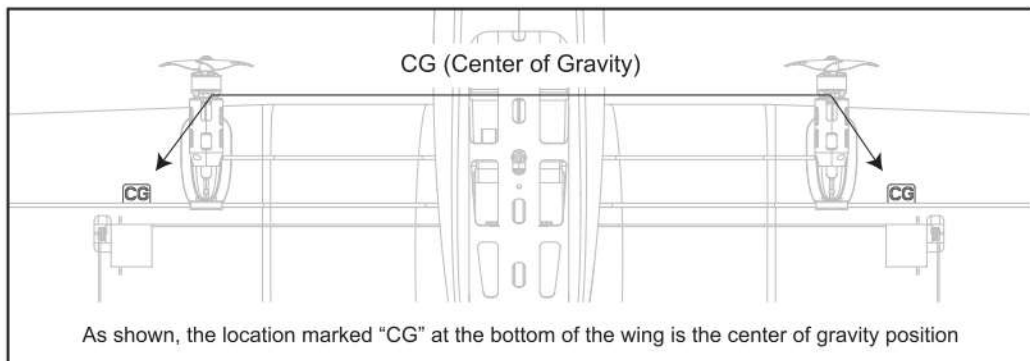

An aircraft with the correct CG has its weight balanced on the center of the aircraft for safe and stable flight. The aircraft's CG and weight are based on having the **recommended** battery installed. (7.4V 2S 650mAh 20C Li-Po Battery, 35g)

The CG location is marked on the bottom of the wing with a raised "CG". Balance the aircraft on your fingertips at the carbon tube and **adjust the battery position as needed to get the aircraft to balance correctly.**

- If the nose goes down, move the flight battery back until the aircraft balances.
- If the nose goes up, move the flight battery forward until the aircraft balances.

Pre-Flight Checklist

Always turn the transmitter (required to complete) on first

Make sure the transmitter controls are neutral, the throttle is at the lowest position and set the THROTTLE CUT switch on the transmitter to the RED DOT position

Plug the flight battery into the aircraft and place it on a level and in an unobstructed open field

Check the aileron movement

Push the aileron stick left, left wing will tilt up and right wing will tilt down

Push the aileron stick right, left wing will tilt down and right wing will up

Check the elevator movement

Push the elevator stick up, the back edge of left and right horizontal tail will tilt down

Push the elevator stick down, the back edge of left and right horizontal tail will tilt up

Check the rudder movement

Push the rudder stick left to point the nose of aircraft left

Push the rudder stick right to point the nose of aircraft right

Check the Alignment

Keep the throttle at zero and aileron, rudder, elevator to neutral. All the wing, horizontal tail and vertical fin should align to the aircraft. Adjust the pushrod of the servo if one of them do not align to the aircraft. Refer to the "Control Surface Centering" for more information

If the aircraft control surfaces do not respond as above, DO NOT FLY

Flying Checklist

Always turn the transmitter (required to complete) on first

Make sure the transmitter controls are neutral, the throttle is at the lowest position and set the THROTTLE CUT switch on the transmitter to the RED DOT position

Plug the flight battery into the aircraft, place it on a level surface and let it to initialize

Do not touch the aircraft after plugging the flight battery and let it to initialize. The LED (green) and (blue) on the multi control unit will glow solid. Secure the flight battery with the hook and loop strap, then put back the battery hatch after the aircraft initialized successfully

Place the aircraft in an unobstructed open field and takeoff with upwind (if there is wind)

Stand on a safe, unobstructed and well-viewed area

Set the THROTTLE CUT switch on the transmitter to the GREEN DOT position

Push the throttle Stick up and push down the elevator Stick, fly the aircraft

Take off to a suitable height and start to control the two sticks to let the aircraft fly in the desired trajectory

Land the aircraft

Unplug the flight battery then turn the transmitter (required to complete) off last

Skill 1: Ensure not to tilt the throttle stick and maintain in the center when taking off

It help the aircraft keep steady during the take-off period

Skill 2: During the take-off period, push the throttle higher and pull the elevator lower will shorten the take-off time

Skill 3: Find an unobstructed open field to land the aircraft. Begin the landing by lower the throttle and descending towards the runway

Once the aircraft about to touchdown, gently pull back the elevator to raise the nose and flair for a gentle landing

Multi Control Unit Wiring Diagram

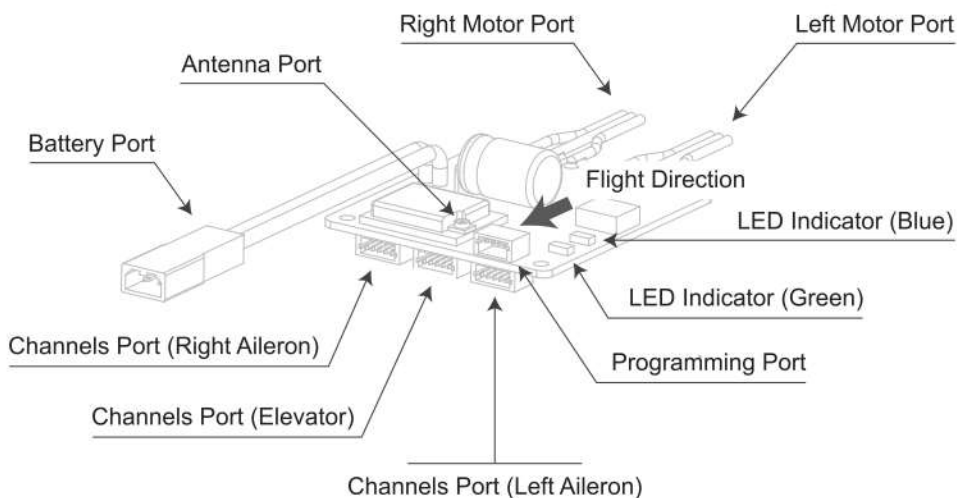

Transmitter and Receiver Binding

- 1) Power off the transmitter and power on the aircraft, the LED (Blue) on the multi control unit (Eyas II Mini) from flashes rapidly to glow solid and the LED (Green) flashes rapidly, which shows the multi control unit is in bind mode.
- 2) Push and hold the rudder trim to the right, then press and hold the power switch of the transmitter.
- 3) The LED (green) on the multi control unit will glow solid and the transmitter beep one time when binding is complete. Then release the rudder trim button and power switch.

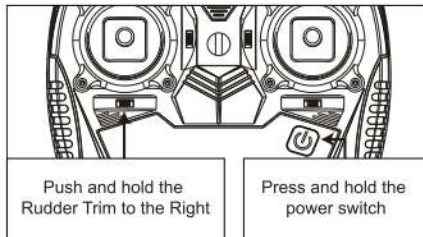

Troubleshooting Guide

Situation: Aircraft does not operate

Solution: Please check the following

- Step 1 - Turn the transmitter on first always, then plug the flight battery into the aircraft.
- Step 2 - Rebind transmitter to the aircraft (multi control unit green and blue LED will glow solid).
- Step 3 - Servo channel connectors must plug in the correct port in the multi control unit.

Situation: Aircraft compatible with other batteries

Solution: The included 7.4V 650mAh 2S 20C Li-ion Battery is highly recommended to use. The capacity, dimensions and weight for other batteries should be similar to place in the fuselage.

Situation: Motor do not spin after Initialize successfully and servo works normally

Solution: Throttle cut function is activated, refer to the "Flying Checklist" for more information.

If you need further assistance, contact the Esky Hobby product support department by email

MINI 6X Transmitter - Mode2 (Required to complete)

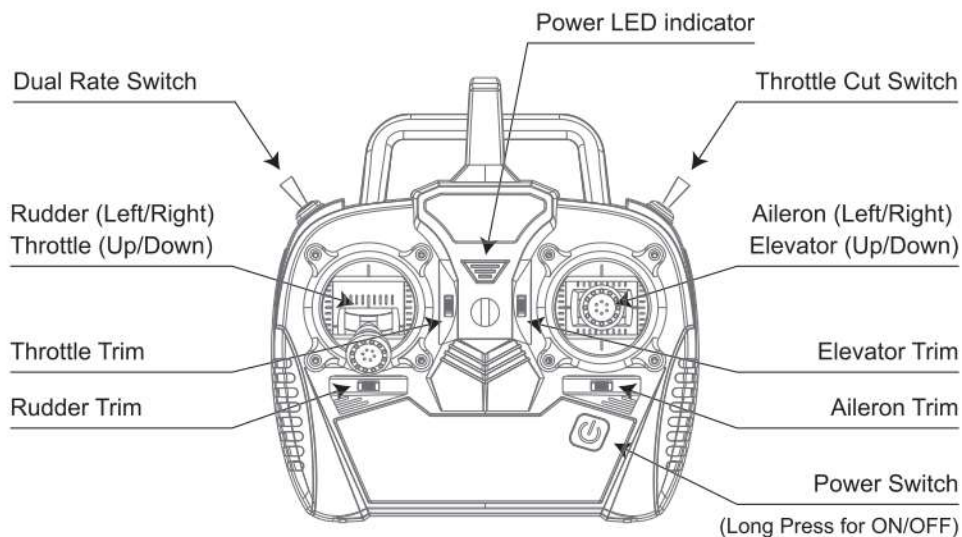

MINI 6X Transmitter - Mode1 (Required to complete)

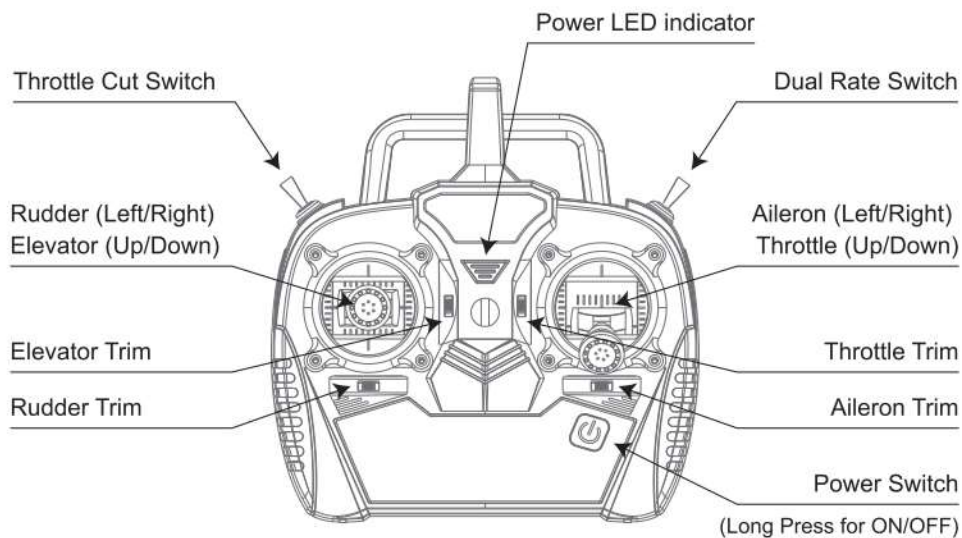

MINI 6X Transmitter Control Direction - Mode2 (Required to complete)

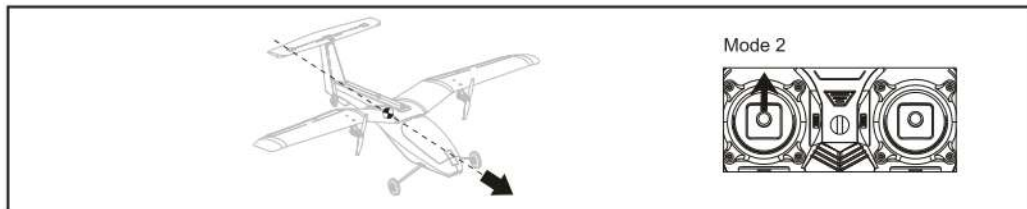

Push the "Left Stick" up, the aircraft motor speeds up to make the aircraft go faster.
When pushing the "Left Stick" down, the aircraft motor speeds down and slow down the aircraft.
This procedure is Throttle Control.

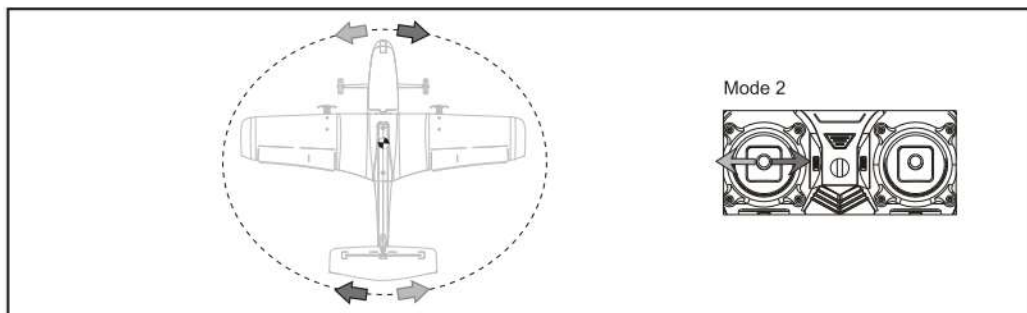

Push the "Left Stick" left or right to point the nose of the aircraft left or right.
The rudder stick is also used to steer the aircraft left and right while taxiing on the ground. This procedure is Rudder Control.

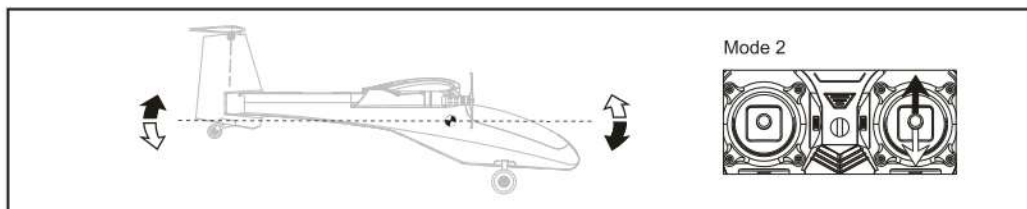

Push the "Right Stick" up to make the aircraft go down.
Push the "Right Stick" down to make the aircraft go up. This procedure is Elevator Control.

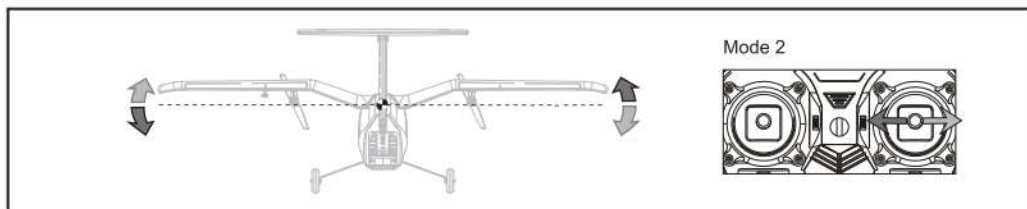

Push the "Right Stick" left to make the aircraft roll or bank left,
Push the "Right Stick" right to make the aircraft roll or bank right. This procedure is Aileron Control.

MINI 6X Transmitter Control Direction - Mode1 (Required to complete)

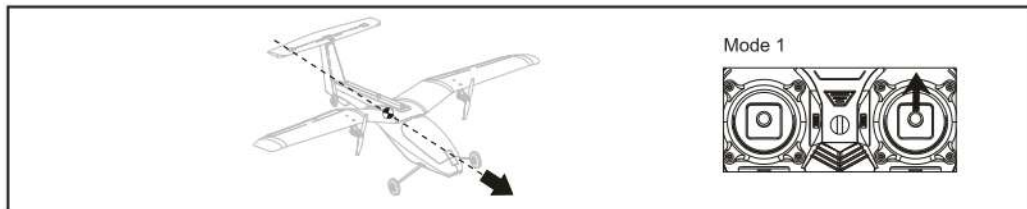

Push the "Right Stick" up, the aircraft motor speeds up to make the aircraft go faster.
When pushing the "Right Stick" down, the aircraft motor speeds down and slow down the aircraft.
This procedure is Throttle Control.

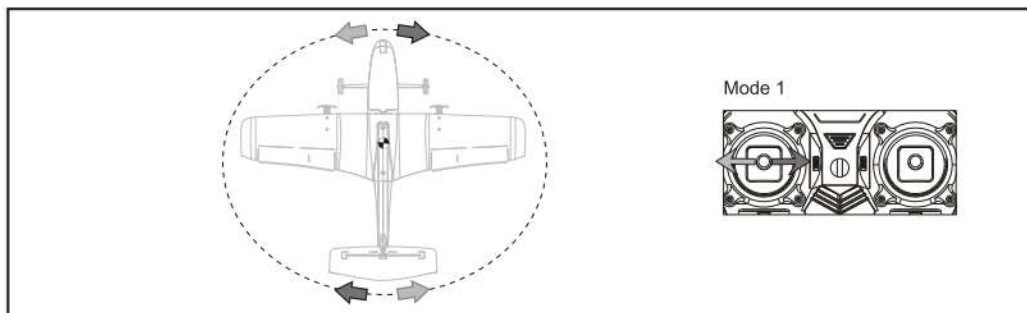

Push the "Left Stick" left or right to point the nose of the aircraft left or right.
The rudder stick is also used to steer the aircraft left and right while taxiing on the ground. This procedure is Rudder Control.

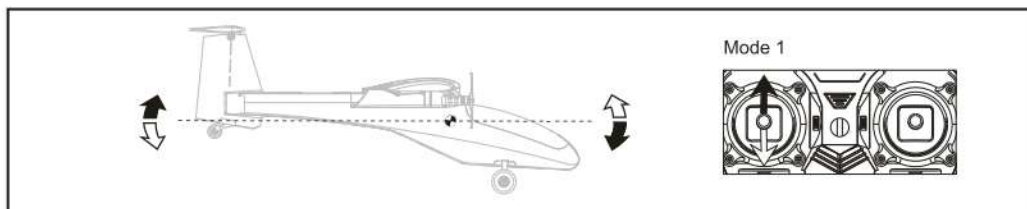

Push the "Left Stick" up to make the aircraft go down.
Push the "Left Stick" down to make the aircraft go up. This procedure is Elevator Control.

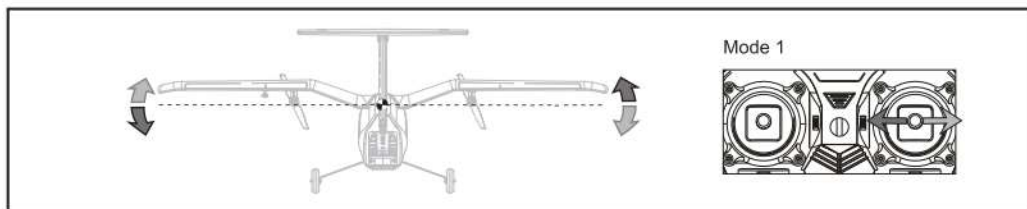

Push the "Right Stick" left to make the aircraft roll or bank left,
Push the "Right Stick" right to make the aircraft roll or bank right. This procedure is Aileron Control.

Parts Listing

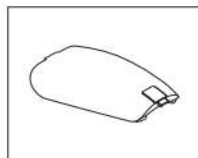

ESKY009109

Hatch

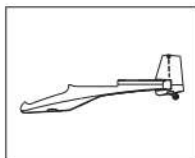

ESKY009110

Fuselage Set

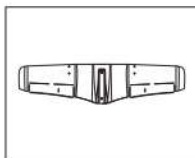

ESKY009111

Wing Set

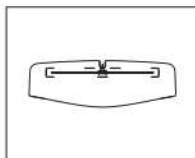

ESKY009112

Horizontal Fin Set

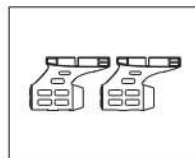

ESKY009113

Motor Mount Set

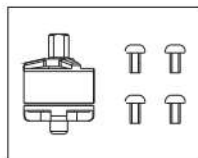

ESKY009114

Brushless Motor (L)

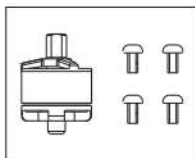

ESKY009115

Brushless Motor (R)

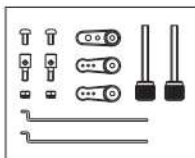

ESKY009116

Hardware Set

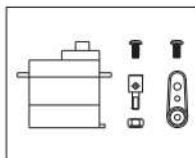

ESKY009117

5 Wire Aileron Servo

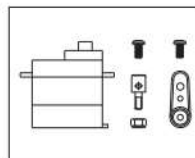

ESKY009118

5 Wire Elevator Servo

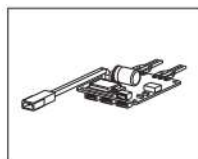

ESKY009119

Multi Control Unit

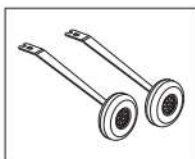

ESKY008456

Main Landing Gear

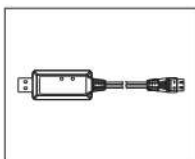

ESKY005907

USB Charger

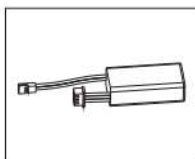

ESKY008565

Li-Po Battery



ESKY008083

MINI 6X Transmitter
(Mode 2)

ESKY008083a

MINI 6X Transmitter
(Mode 1)

ESKY008725

ECH6 Transmitter
(Mode 2)

ESKY008725a

ECH6 Transmitter
(Mode 1)

安全注意事项和警告

本产品是通过无线电信号控制的，在操作时可能会受到其他无线电信号干扰，此干扰可能会影响本产品性能甚至会导致本产品失控。

警告

1. 本产品具有一定的危险性，禁止14岁以下人士进行操作！
2. 不要将产品直接暴露在火或者对温度有影响的热源下。
3. 建议在5-35度，相对湿度20%-80%的环境中使用此产品。
4. 建议在没有风扇，冷气机，台灯或其他危险物件的地方操作此产品。
5. 电机为发热部件，请勿触摸，以免烫伤。

禁止

1. 飞行时要远离人群，避免旁人围观！以免误伤他人！
2. 本产品内部是由许多精密的电子零件组成，因此必须保证防潮防水，避免在浴室或雨雾天气时使用，以免水气进入机体内部导致机器零件或电子零件故障而引发不可预测的意外。
3. 请勿对本产品进行任何改装或拆解。
4. 本产品在空中飞行时禁止用手或其他物品触及本产品的任何部位！避免造成不必要损失及人身伤害！

目录

产品参数 & 配置 & 包装内容	16
飞行电池充电方法	17
飞机零件介绍	17
主起落架组装	18
平尾组装	18
机翼组装	19
舵面手动调整	20
重心调整方法	21
起飞检查	21
飞行操作步骤	22
复合控制器接线示意图	22
对码方法	23
飞行中的异常排除	23
MINI 6X 左手发射机介绍 - Mode 2 (BTF包装不包含发射机)	24
MINI 6X 右手发射机介绍 - Mode 1 (BTF包装不包含发射机)	24
MINI 6X 左手发射机控制说明 - Mode 2 (BTF包装不包含发射机)	25
MINI 6X 右手发射机控制说明 - Mode 1 (BTF包装不包含发射机)	26
配件表	27

产品参数

翼展	760mm	飞行时间	8-15分钟
全长	643mm	主体材质	EPO
起飞重量	247g	电池接头	JST SYP 2.5mm 2-Pin

配置 (BTF)

电机	无刷 1104-4275Kv	接收机	ESKY复合控制系统
电调	15A BEC 3A	飞控	ESKY复合控制系统
电池	2S 650mAh 20C	充电器	2S平衡充电器
舵机	4.3克数字舵机 x3	发射机	无

(MINI 6X或ECH6六通道发射机)

包装内容

1 x 机翼 (含动力组)	1 x 平尾
1 x 机身	2 x 主起落架
1 x 2S平衡充电器	1 x 2S 650mAh锂电池
2 x 机翼固定螺栓	

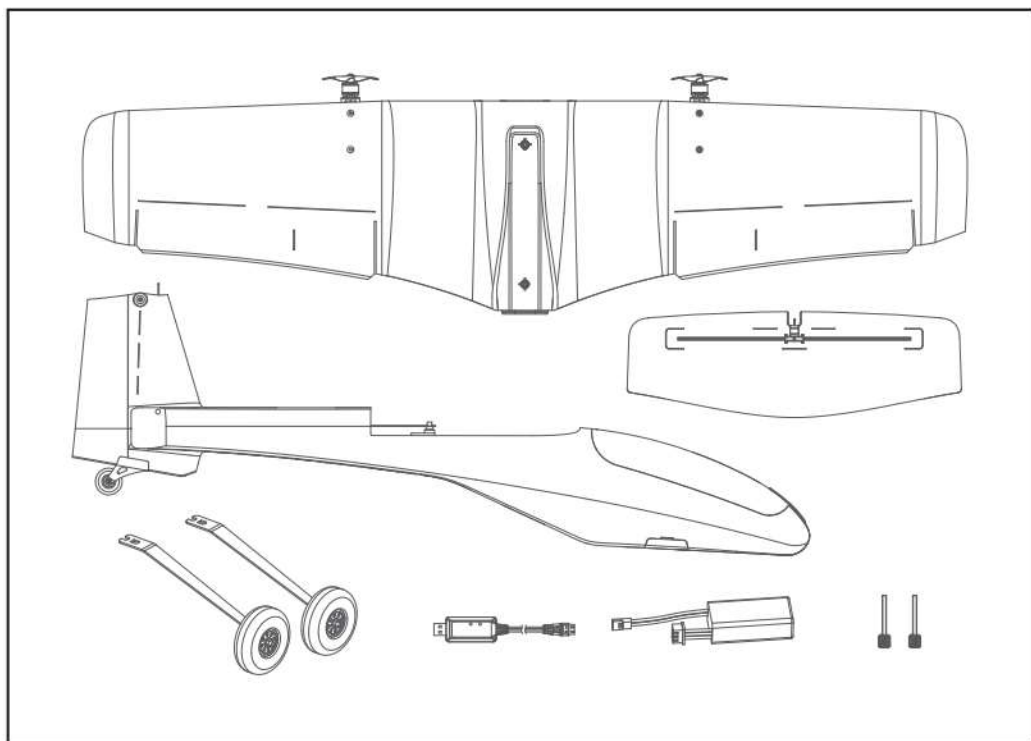

飞行电池充电方法

- 1) 将7.4V 2S LiPo电池插入充电器，然后将充电器插入USB端口或USB电源。
- 2) 充电器上的红色LED灯常亮，同时绿色LED灯闪烁，表明充电已开始。
- 3) 电池充满时，红色和绿色LED灯都变为常亮。

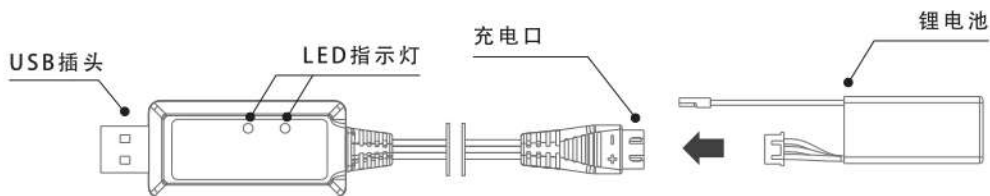

红色LED灯常亮且绿色LED灯闪烁：正在充电
 红色和绿色LED灯常亮：充电完成
 仅红色LED灯常亮：电源已连接（待机）

仅红色LED灯闪烁：电池异常
 红色和绿色LED灯闪烁：充电器异常
 红色LED灯闪烁且绿色LED灯常亮：输入电压过高

飞机零件介绍

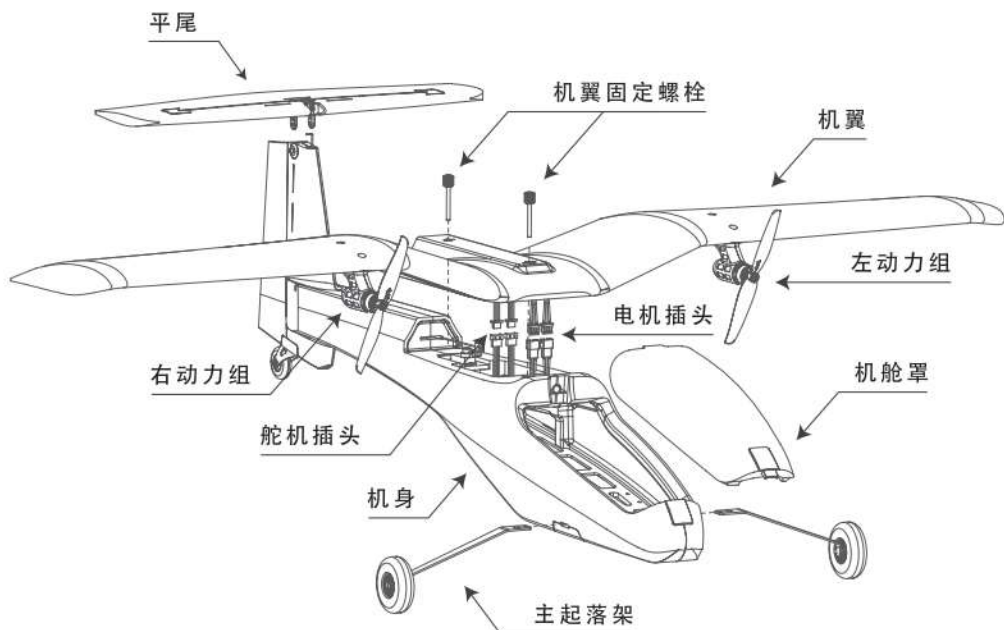

主起落架组装

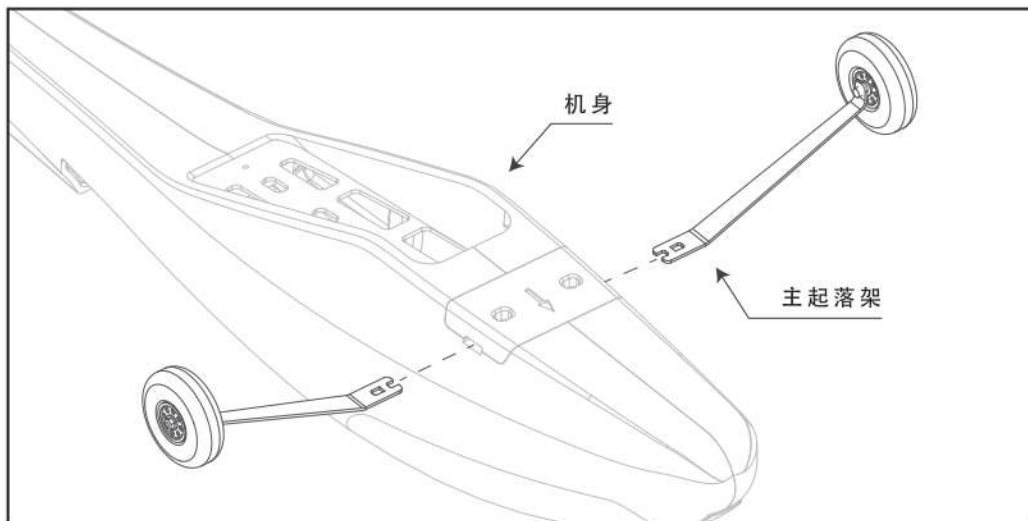

将起落架插入机身下的插槽，向里滑动直至其卡扣锁定，主起落架组装完成。

平尾组装

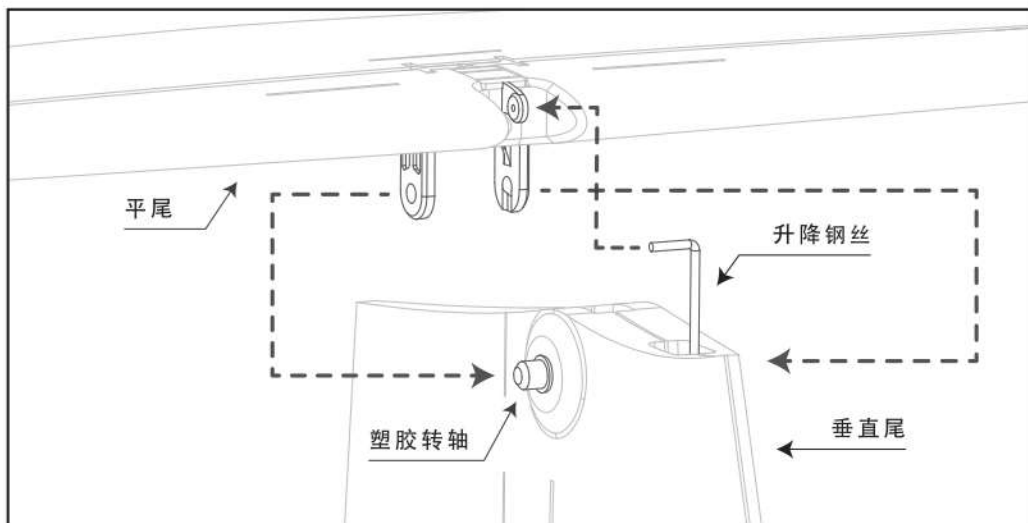

将平尾卡入垂尾顶部的塑胶转轴上，并将钢丝头扣入对应孔位上，平尾组装完成。

机翼组装

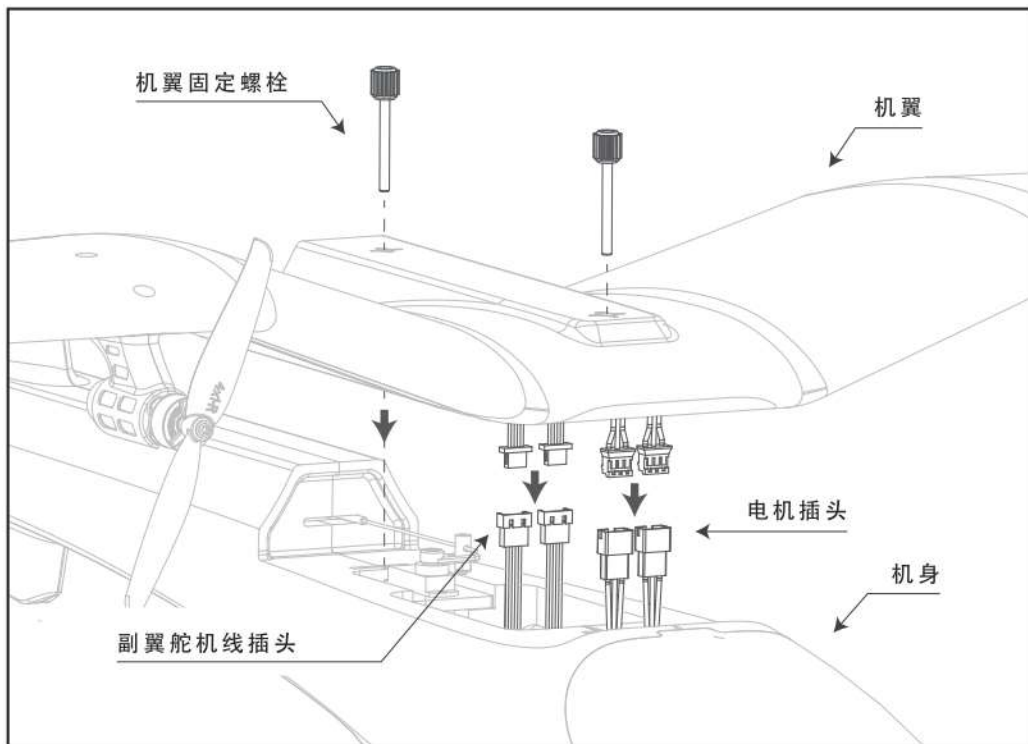

正确连接好左、右副翼舵机插头，左、右电机插头，将机翼安放在机身中部的对应位置上，并使用塑胶头螺栓将机翼固定在机身上，机翼组装完成。

(注意：确保副翼舵机线及其插头和电机线及其插头不得压在机身与机翼之间)

至此，Seagull组装完成。

舵面手动调整 (飞机在出厂时已调整好)

特别说明, 调整各舵面之前, 先关闭发射机, 然后给飞机接通电源, 此时各舵机会自动回到中立位置, 在此状态下进行舵面的调整。(工具: 随机附带的“L”型内六角扳手)

副翼调整

副翼两端与机翼主体应保持平齐, 不得有明显的错位情况, 如有错位, 需松开机翼下方固定拉杆螺丝, 调整副翼至与机翼主体平齐状态, 并重新拧紧螺丝。

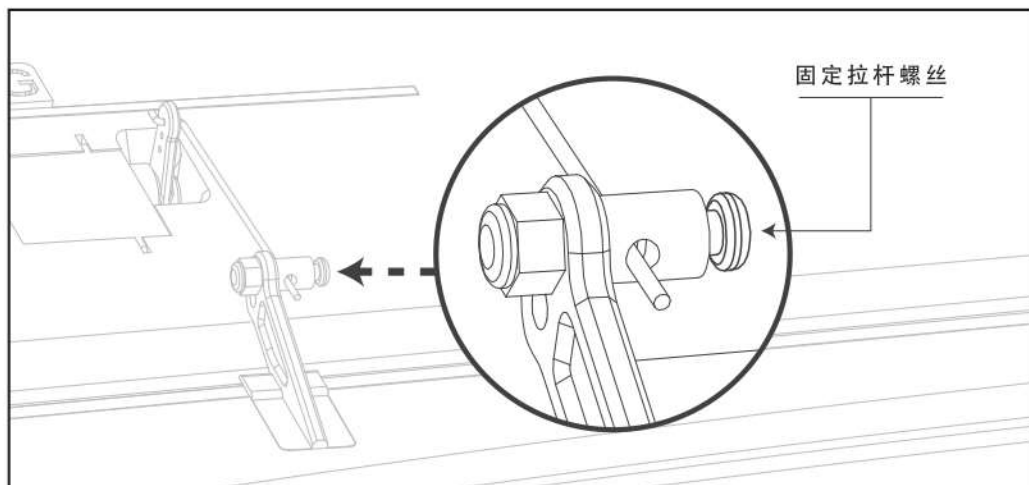

平尾调整

松开机身上方中部升降舵机上的固定拉杆螺丝, 调整平尾下方卡扣侧面上的直线与垂尾侧面上的直线处于同一条直线上 (如下图所示), 此时固定舵机上的拉杆固定螺丝即可。

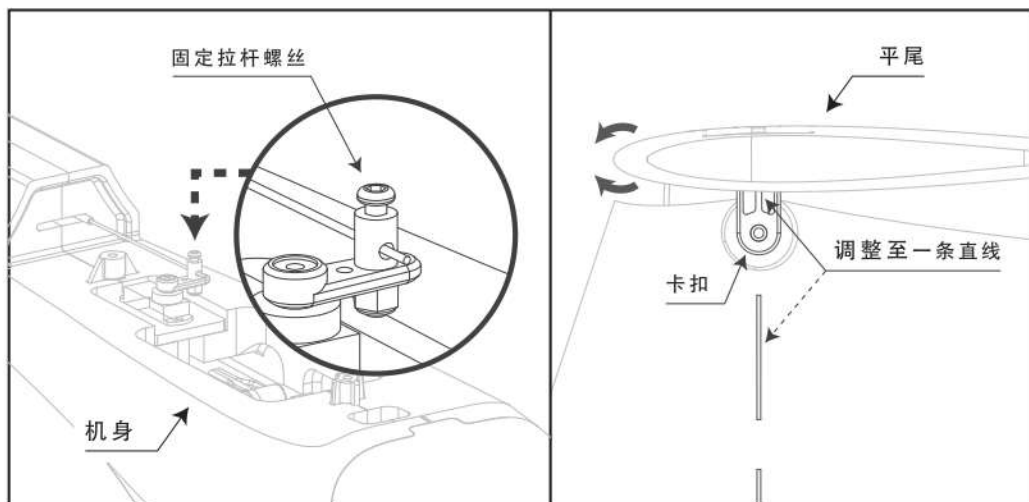

重心调整方法

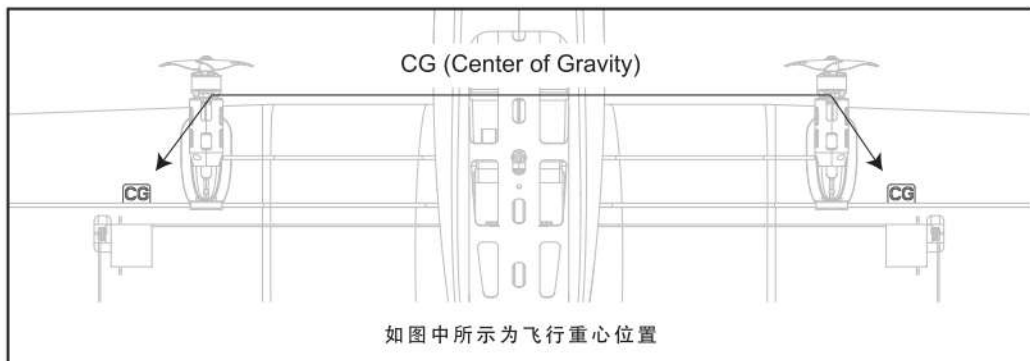

飞机安装完好后(含电池),用双手食指顶住机翼底部CG位置,若此时飞机姿态能够水平或接近水平,则重心正确。若此时飞机低头或抬头,请后移或前移电池的安装位置。若始终无法平衡重心,则电池的重量太轻(飞机始终偏向抬头)或者太重(飞机始终偏向低头),请更换重量合适电池或自己进行配重。请注意!配重后,飞机可能无法在最佳设计性能下飞行。

起飞检查

□ 打开发射机电源

注意把油门杆放在最低位置。油门熄火开关打在红点位置

□ 飞机通电,固定好电池,并把飞机水平摆放在无遮挡的开阔场地中

□ 检查副翼动作(站在飞机后方,面朝飞行方向)

往左操纵副翼摇杆,机翼左边副翼往上偏转,右边副翼往下偏转
往右操纵副翼摇杆,则偏转方向相反。

□ 检查升降动作(站在飞机后方,面朝飞行方向)

往前推升降舵摇杆,平尾的尾部朝下偏转,往后拉升降舵摇杆,平尾的尾部朝上偏转

□ 检查航向动作(站在飞机后方,面朝飞行方向)

此款飞机航向是通过左右电机差速进行控制,无方向舵

在检查此功能前,需将油门熄火开关打在绿点位置上,此时左右电机会低速开始转动
往左操纵方向舵摇杆,飞机往左偏转,往右操纵方向舵摇杆,飞机往右偏转

□ 检查舵面齐整情况

在发射机油门最低,方向杆,副翼杆,俯仰杆居中情况下,副翼应与主翼面平整,不应该与连接的机翼面成台阶。若出现台阶,请参看后面的"舵面手动调整"调整舵机拉杆至机翼齐整。

如果任何一个控制舵面没有按以上指示动作,请务必不要飞行!

然后查看后面的问题排解,若有必要,可联系忠达模型售后服务中心进行咨询。

如果飞机正确按照上面指示动作正确,请前往"MINI 6X发射机控制说明"

飞行操作步骤

□ 务必打开发射机(BTF包装不包含发射机)电源

确保发射器左右摇杆处于中位，油门处于最低位置
将发射机上的“油门熄火开关”拨动到红点位置。

□ 给飞机装上飞行电池，并通电，放平，静待自检完成

飞机通电之后，马上放在水平面上不要动飞机，静待飞机自检完成。
飞机自检完成后，绑好电池并盖上电池仓盖。

□ 把飞机摆放到开阔场地，若有风，则机头需逆风摆放(需逆风起飞)

飞行员找一个安全无遮挡且视线良好的场地站好。

□ 将发射机上的“油门熄火开关”拨动到绿点位置

□ 向上推油门杆，同时向下拉俯仰杆，飞机起飞

起飞到合适高度，开始控制两个摇杆让飞机按照自己希望的轨迹飞行。

□ 飞行结束，降落飞机

飞机断开电池连接，关闭发射机电源。

小技巧1：起飞时推油门杆务必要左右歪，保证飞机起飞阶段不会左右乱跑。

小技巧2：起飞阶段，推油门越高，向下拉俯仰杆越大的话，起飞距离越短，飞机越快离地。

小技巧3：降落时请找开阔场地，修正飞机姿态，收油门，同时根据飞机降落情况向下拉俯仰杆，尽量让飞机的主轮先着地，尾轮后着地。

复合控制器接线示意图

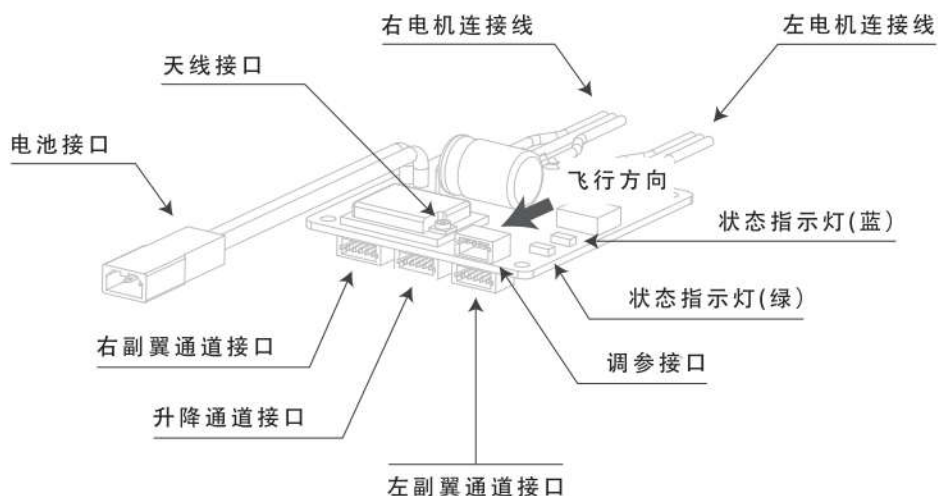

对码方法

- 1) 关闭发射机电源并打开飞机电源，飞机中复合控制器的绿色LED灯会在短时间内快速闪烁。
- 2) 向右按住航向微调键不放并打开发射机电源。
- 3) 当飞机中复合控制器的状态LED(绿色灯)常亮时，表示对码完成，松开航向微调键。

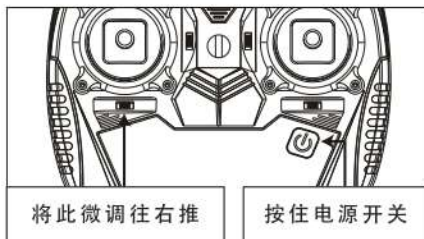

飞行中的异常排除(如果以下方法未能解决问题，请与售后支持联系)

情况: 拨动发射机摇杆，飞机没有反应

解决方法: 请检查以下部位

- 确保发射机打开，飞机处于通电状态。
- 发射机与复合控制接收机是否对频成功(复合控制系统绿色灯务必常亮，蓝灯慢闪)。
- 舵机插头与接收机板对接是否有松动，插接是否到位。

情况: 飞机使用其他电池可以吗?

解决方法: 推荐使用随机附带的650mAh 7.4V 20C电池，也可使用接近此容量并同电压的电池，不过重心需调整在此款飞机指定的位置上，同时电池安放完毕后不得与机舱盖干涉。

情况: 飞机在起飞时或在飞行过程中处于偏航状态，使用微调也没能调整到直线飞行?

解决方法: 检查螺旋桨是否有破损、变形或是松脱。如果螺旋桨没有问题，找出偏航方向。

(偏航方向往左)那么需更换左边电机，(偏航方向往右)那么需更换右边电机。

如果还是偏航，那么需同时更换左右电机。

情况: 为什么自检完成后舵机可以正常操作而电机不转动?

解决方法: 操作步骤错误飞机进入安全保护状态，请按照“起飞检查”第一步进行操作。

MINI 6X 左手发射机介绍 - Mode 2 (BTF包装不包含发射机)

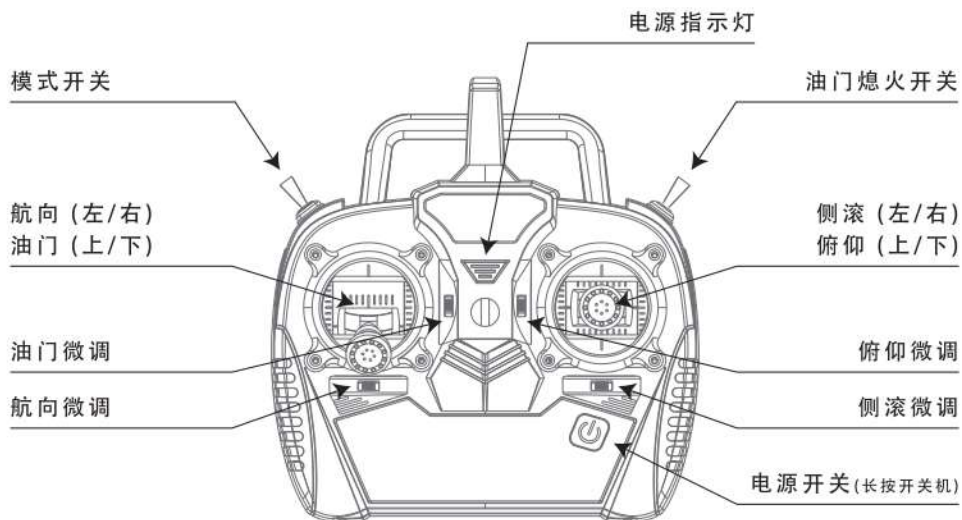

MINI 6X 右手发射机介绍 - Mode 1 (BTF包装不包含发射机)

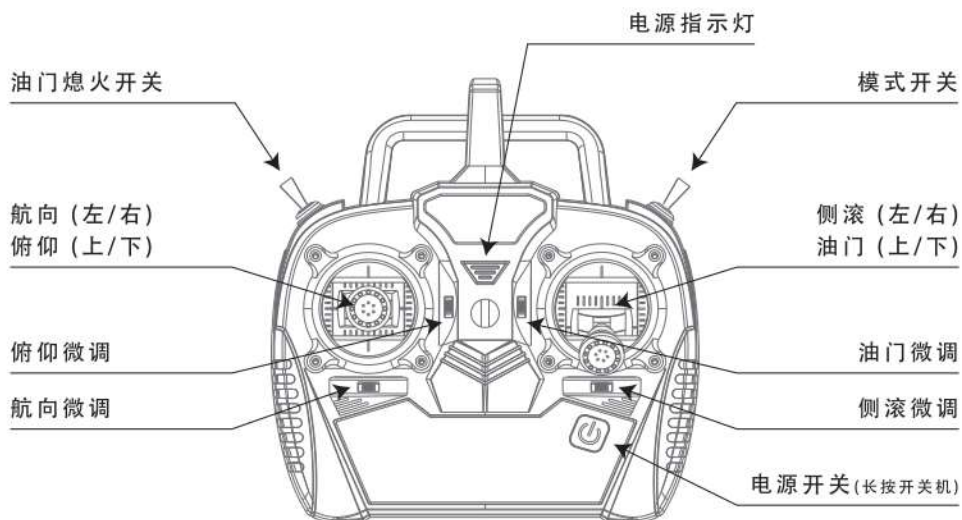

MINI 6X 左手发射机控制说明 - Mode 2 (BTF包装不包含发射机)

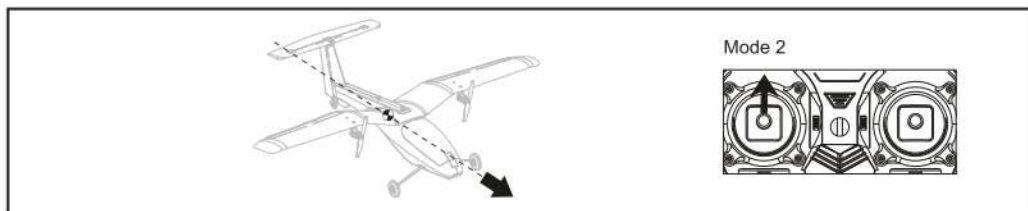

当"左摇杆"向上推动时,飞机马达转速加快并使飞机向前加速飞行。
 当"左摇杆"向下拉动时,飞机马达转速降低并使飞机向前减速飞行。此过程是油门控制。

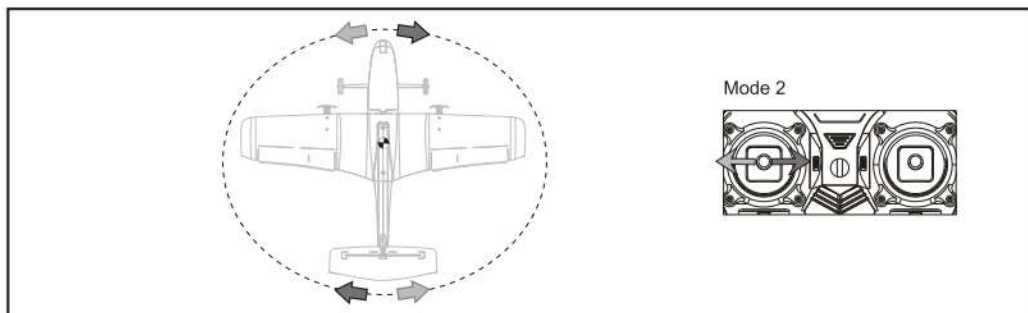

当"左摇杆"向左推动时,飞机向左拐弯。
 当"左摇杆"向右推动时,飞机向右拐弯。此过程是航向控制。

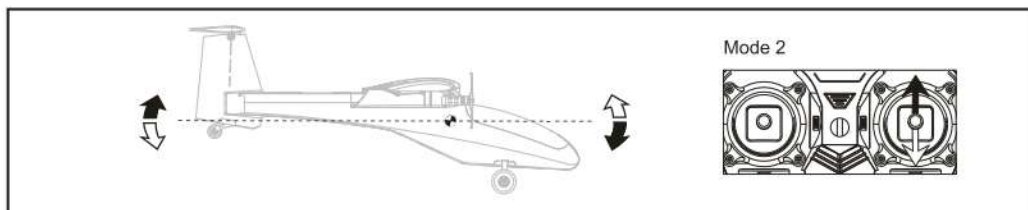

当"右摇杆"向上推动时,飞机低头向下飞行。
 当"右摇杆"向下拉动时,飞机抬头向上飞行。此过程是俯仰控制。

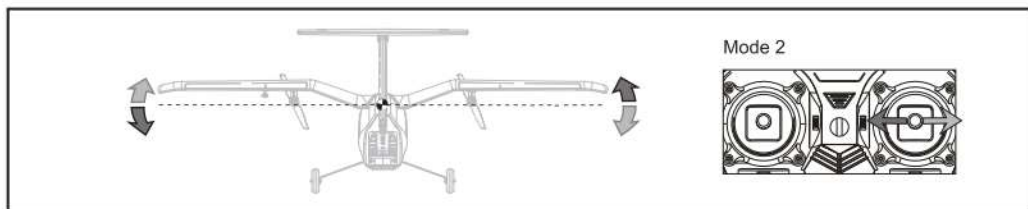

当"右摇杆"向左推动时,飞机向左侧倾斜飞行并有左拐弯现象。
 当"右摇杆"向右推动时,飞机向右侧倾斜飞行并有右拐弯现象。此过程是侧滚控制。

MINI 6X 右手发射机控制说明 - Mode 1 (BTF包装不包含发射机)

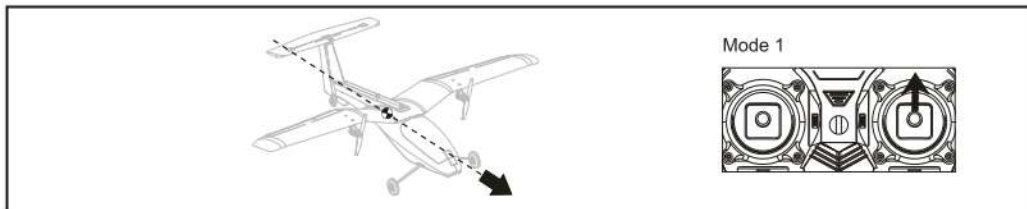

当"右摇杆"向上推动时,飞机马达转速加快并使飞机向前加速飞行。
 当"右摇杆"向下拉动时,飞机马达转速降低并使飞机向前减速飞行。此过程是油门控制。

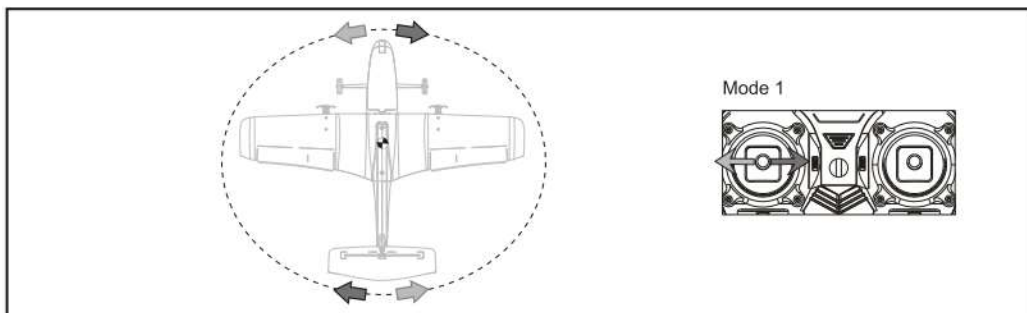

当"左摇杆"向左推动时,飞机向左拐弯。
 当"左摇杆"向右推动时,飞机向右拐弯。此过程是航向控制。

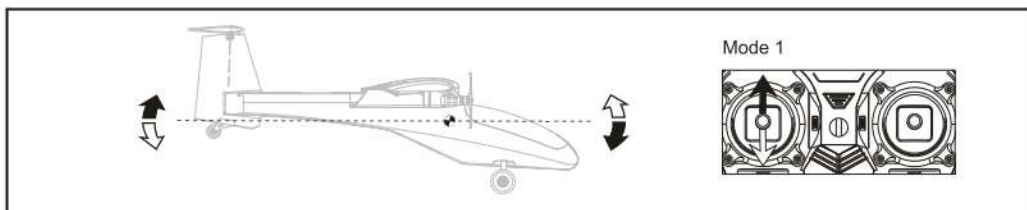

当"左摇杆"向上推动时,飞机低头向下飞行。
 当"左摇杆"向下拉动时,飞机抬头向上飞行。此过程是俯仰控制。

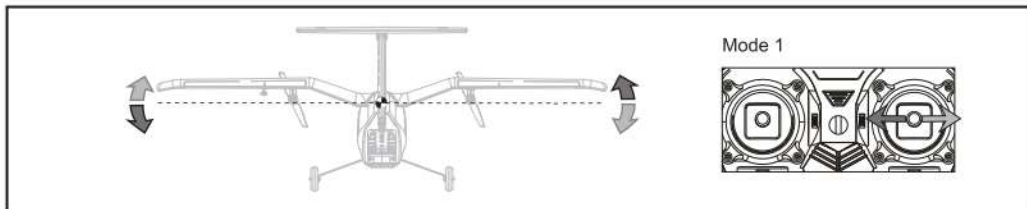

当"右摇杆"向左推动时,飞机向左侧倾斜飞行并有左拐弯现象。
 当"右摇杆"向右推动时,飞机向右侧倾斜飞行并有右拐弯现象。此过程是侧滚控制。

配件表

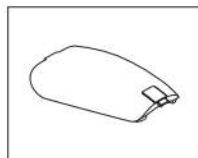

ESKY009109

座舱罩

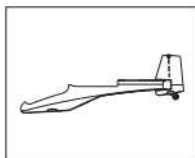

ESKY009110

机身

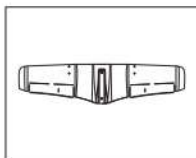

ESKY009111

机翼

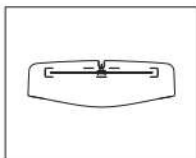

ESKY009112

平尾

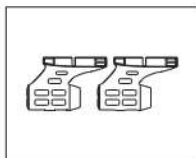

ESKY009113

电机固定座

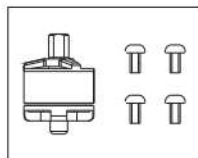

ESKY009114

无刷电机(L)

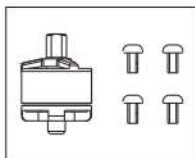

ESKY009115

无刷电机(R)

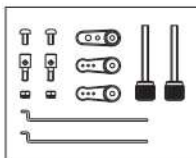

ESKY009116

附件包

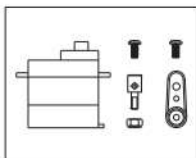

ESKY009117

副翼舵机

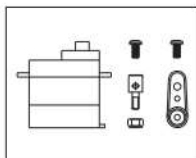

ESKY009118

升降舵机

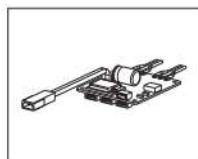

ESKY009119

四合一控制器

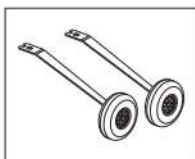

ESKY008456

主起落架

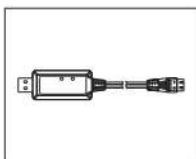

ESKY005907

USB充电器

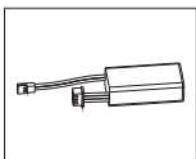

ESKY008565

锂电池



ESKY008083

MINI 6X发射机
(左手油门)

ESKY008083a

MINI 6X发射机
(右手油门)

ESKY008725

ECH6发射机
(左手油门)

ESKY008725a

ECH6发射机
(右手油门)

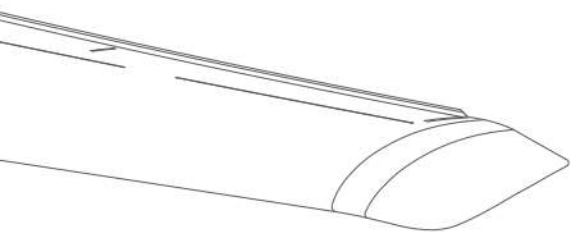
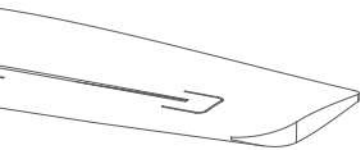

Created 04/24

E_sky[®]

All instructions are subject to change at the sole discretion of Zonda Hobby. For up-to-date product literature, Visit esky-rc.com and click on the support tab for this product.

忠达模型保留更改所有说明的权利，说明及其它附属资料的变更将不另行通知，如需更新或获取更多资讯，请访问esky-rc.com.cn